

TEREX DEMAG AC 50-1

UDŹWIG MAKSYMALNY 50 TON

 **HERKULES**

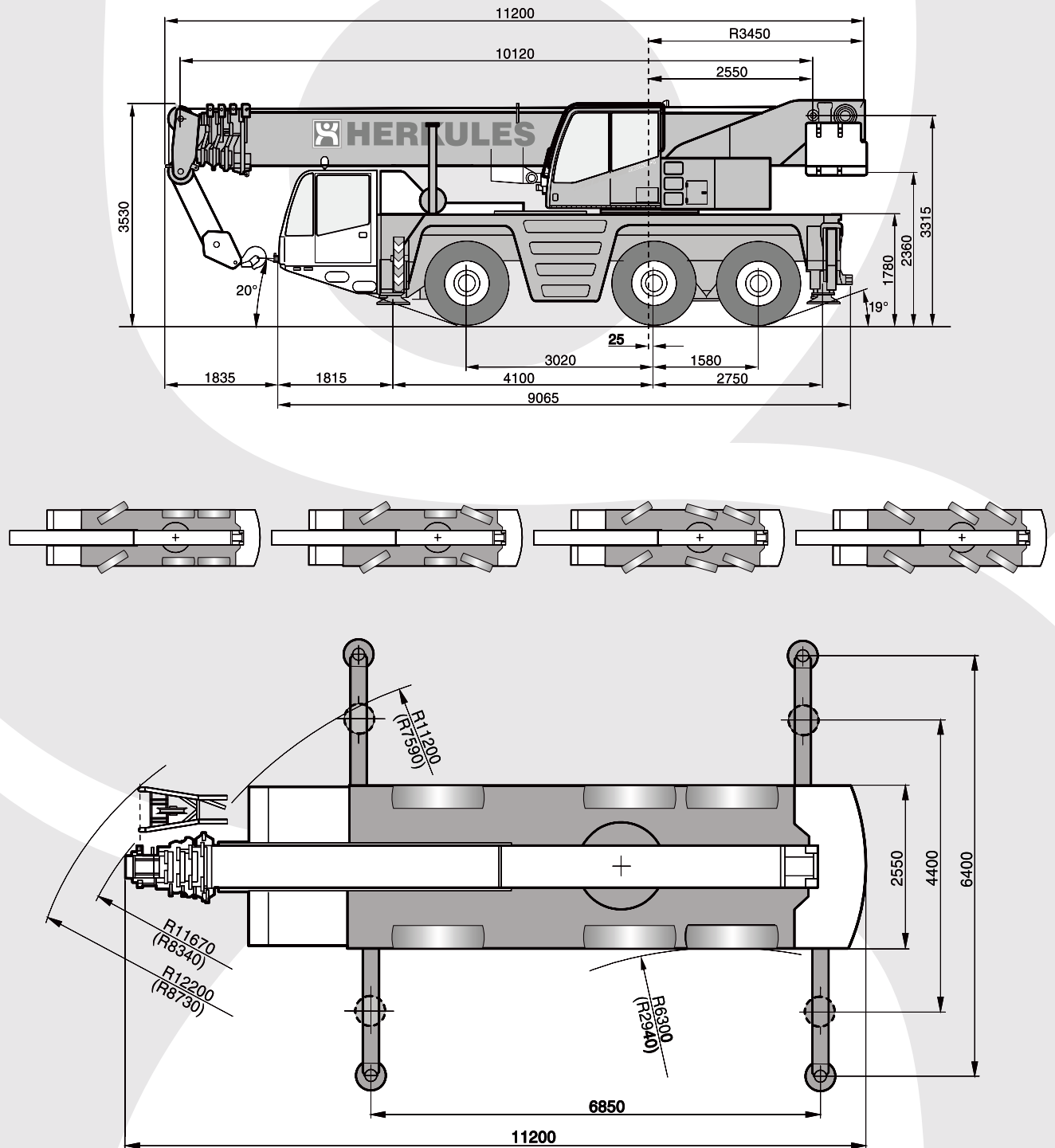

DANE TECHNICZNE:

UDŹWIG MAKSYMALNY: 50 TON
MAKSYMALNA PRZECIWWAGA: 9,5 TON
OBSZAR PRACY: 360°

DŁUGOŚĆ WYSIĘGNIA
PODSTAWOWEGO: 40 M
POMOCNICZEGO STAŁEGO: 17,6 M

TEREX DEMAG AC 50-1

UDŹWIG MAKSYMALNY 50 TON

HERKULES



10,1 m - 40 m



360°





9,5 t



DIN ISO

Tabela udźwągów żurawia TEREX DEMAG AC 50-1 - wysięgnik podstawowy + 9,5 tony przeciwwagi

 m	10,1 m	16,1 m	22,1 m	28,0 m	32,5 m	37,0 m	40 m	 m
3	50,0 *							3
3	45,7							3
3,5	41,6	28,0						3,5
4	38,1	28,0	17,0					4
4,5	35,2	28,0	17,0	14,0				4,5
5	32,6	28,0	17,0	14,0	11,0			5
6	26,4	25,0	17,0	14,0	11,0	9,0		6
7	21,7	20,6	17,0	14,0	11,0	9,0	7,0	7
8		16,0	16,0	13,1	11,0	9,0	7,0	8
9		14,6	14,5	12,3	10,5	9,0	7,0	9
10		12,3	12,4	11,5	10,0	9,0	7,0	10
12		9,1	9,5	9,0	8,9	8,0	7,0	12
14			7,4	7,6	7,0	7,1	6,3	14
16			6,0	6,1	5,6	5,6	5,6	16
18			4,9	5,1	4,9	4,8	4,6	18
20				4,2	4,3	4,0	3,7	20
22				3,6	3,7	3,3	3,0	22
24				3,0	3,1	2,7	2,5	24
26					2,6	2,3	2,0	26
28					2,2	1,9	1,6	28
30						1,5	1,3	30
32						1,2	0,9	32
34							0,7	34



37 m



od 9,2 m do 17,6 m



360°



9,5t



40 m



od 9,2 m do 17,6 m



360°



9,5t

Tabela udźwągów żurawia TEREX DEMAG AC 50-1
Wysięgnik podst. 37 m + wysięgnik pomoc.



 m	9,2 m			17,6 m			
	0°	20°	40°	0°*	0°	20°	40°
8	4,1						
9	4,1						
10	4,1		-	1,8			
12	4,1	3,7		1,8			
14	4,0	3,5	3,2	1,8			
16	3,9	3,4	3,1	1,8	1,8		
18	3,7	3,2	3,0	1,8	1,7		
20	3,5	3,1	2,9	1,8	1,6		
22	3,1	2,9	2,8	1,7	1,6	1,5	
24	2,6	2,8	2,8	1,7	1,5	1,5	
26	2,1	2,4	2,5	1,6	1,5	1,4	
28	1,7	1,9	2,1	1,5	1,4	1,4	
30	1,4	1,6	1,7	1,5	1,4	1,3	
32	1,1	1,2	1,4	1,2	1,3	1,3	
34	0,8	1,0	1,1	1,0	1,3	1,2	
36	0,6	0,7		0,8	1,0	1,2	
38					0,8	1,0	
40					0,6	0,8	
42							

Tabela udźwągów żurawia TEREX DEMAG AC 50-1
Wysięgnik podst. 40 m + wysięgnik pomoc.

 m	9,2 m			17,6 m			
	0°	20°	40°	0°*	0°	20°	40°
9	3,1						
10	3,1			1,5	1,1		
12	3,1	3,1		1,5	1,1		
14	3,1	3,1		1,5	1,1		
16	3,1	3,0	2,9	1,5	1,1	1,1	
18	3,1	2,9	2,8	1,5	1,1	1,1	
20	3,1	2,7	2,6	1,5	1,1	1,1	
22	3,0	2,6	2,5	1,5	1,1	1,1	1,1
24	2,5	2,5	2,4	1,5	1,1	1,1	1,1
26	2,1	2,3	2,3	1,5	1,1	1,1	1,1
28	1,7	1,9	2,1	1,5	1,1	1,1	1,1
30	1,3	1,5	1,7	1,4	1,1	1,1	1,1
32	1,0	1,2	1,3	1,1	1,1	1,1	1,1
34	0,8	0,9	1,0	0,9	0,9	1,1	1,1
36	0,6	0,7	0,8	0,7	0,7	1,0	1,1
38						0,8	1,0
40						0,6	0,7
42							
44							

TEREX DEMAG AC 50-1

UDŹWIG MAKSYMALNY 50 TON



Zasięg pracy: wysięgnik podstawowy

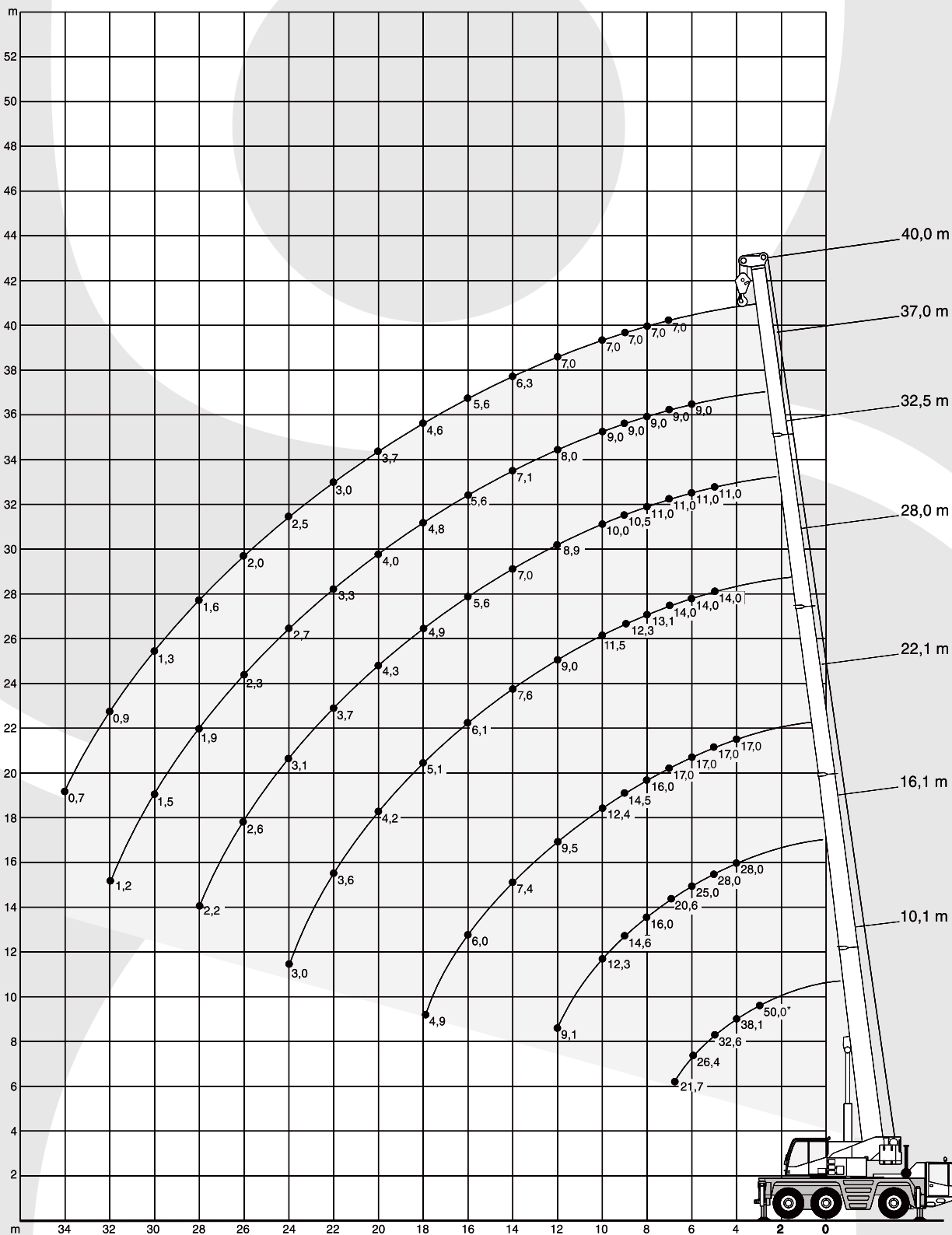

TEREX DEMAG AC 50-1

UDŹWIG MAKSYMALNY 50 TON



Zasięg pracy: wysięgnik podstawowy + wysięgnik pomocniczy

